

### **BorgWarner fournira à un constructeur chinois un module de propulsion intégré 7-en-1**

- *Module de Propulsion intégré (iDM) 7-en-1 personnalisé pour la prochaine génération de technologie hybride*
- *Technologie innovante : meilleures performances et efficacité de conduite accrue*
- *L'intégration des fonctions permet des économies de coûts*

Auburn Hills, Michigan, 12 novembre, 2025 – BorgWarner fournira son module de propulsion intégré 7-en-1 (iDM) à un constructeur chinois de premier plan. Conçu spécifiquement pour le SUV hybride de la marque, l'iDM de BorgWarner regroupe plusieurs fonctions au sein d'un module compact afin d'améliorer les performances et l'efficacité globales du système. Le lancement de la production est prévu pour 2026.

« Notre expertise des composants et des systèmes nous place idéalement pour développer une architecture iDM hautement efficace et personnalisée pour l'application hybride de notre client », a déclaré Stefan Demmerle, Vice President of BorgWarner Inc. and President and General Manager, PowerDrive Systems. « Nous sommes fiers de fournir notre technologie à un constructeur de premier plan dans la région. »

L'iDM 7-en-1 de BorgWarner combine deux moteurs électriques avec la technologie brevetée de bobinage hairpin haute tension, un onduleur double intégrant un chargeur embarqué (OBC), un convertisseur DC-DC, un amplificateur de tension de batterie (boost), une unité de contrôle véhicule (VCU) et une unité de distribution d'énergie (PDU), ainsi qu'une transmission eGear – le tout dans un seul module compact. Chaque composant est scalable pour une grande flexibilité de conception, avec un haut niveau d'intégration et d'efficacité. Le système prend en charge jusqu'à 160 kW, avec une tension maximale de 450 V, délivre un couple de traction de pointe supérieur à 3 400 Nm et atteint un moment de couple maximal de 1 350 tr/min.

Forte d'une expertise approfondie en propulsion électrifiée et de capacités internes couvrant e-machines, électronique de puissance et boîtes de vitesses, BorgWarner propose des solutions flexibles et hautement intégrées, adaptées aux besoins des clients. Grâce à une qualité produit éprouvée, des capacités techniques solides et une collaboration étroite avec les FEO,

BorgWarner Inc. (BorgWarner fournira à un constructeur chinois un module de propulsion intégré 7-en-1) – 2

l'entreprise reste engagée à faire progresser la technologie et à soutenir le développement rapide du marché chinois des véhicules à énergies nouvelles.

### À propos de BorgWarner

Depuis plus de 130 ans, BorgWarner, leader mondial, innove avec succès dans le domaine de la mobilité. Nous mettons l'accent sur le développement durable et contribuons à construire un avenir plus propre, plus sain et plus sûr pour tous.

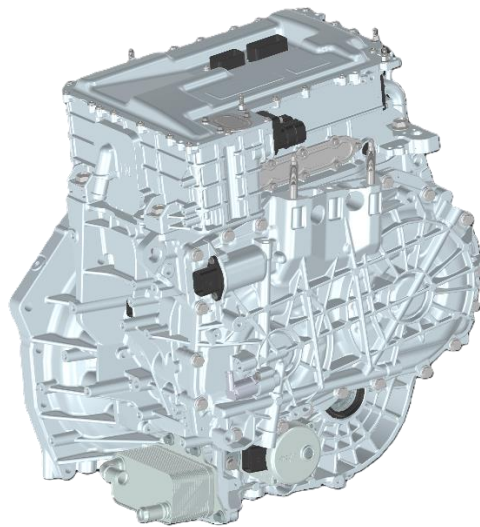

BorgWarner fournira à un constructeur chinois en 2026 un module de propulsion intégré 7-en-1

**Forward Looking Statements:** This release may contain forward-looking statements as contemplated by the 1995 Private Securities Litigation Reform Act that are based on management's current outlook, expectations, estimates and projections. Words such as "anticipates," "believes," "continues," "could," "designed," "effect," "estimates," "evaluates," "expects," "forecasts," "goal," "guidance," "initiative," "intends," "may," "outlook," "plans," "potential," "predicts," "project," "pursue," "seek," "should," "target," "when," "will," "would," and variations of such words and similar expressions are intended to identify such forward-looking statements. Further, all statements, other than statements of historical fact, contained or incorporated by reference in this release that we expect or anticipate will or may occur in the future regarding our business strategy, goals, plans, references to future success and other such matters, are forward-looking statements. All forward-looking statements are based on assumptions and analyses made by us in light of our experience and our perception of historical trends, current conditions and expected future developments, as well as other factors we believe are appropriate under the circumstances. Forward-looking statements are not guarantees of performance, and the Company's actual results may differ materially from those expressed, projected or implied in or by the forward-looking statements.

You should not place undue reliance on these forward-looking statements, which speak only as of the date of this release. Forward-looking statements are subject to risks and uncertainties, many of which are difficult to predict and generally beyond our control, that could cause actual results to differ materially from those expressed, projected or implied in or by the forward-looking statements. These risks and uncertainties, among others, include: evolving legal, regulatory, and tax regimes; the supply disruptions impacting us or our customers, commodity availability and pricing,

## BorgWarner Inc. (BorgWarner to Supply Leading Chinese OEM with 7-in-1 Integrated Drive Module) – 3

and an inability to achieve expected levels of recoverability in commercial negotiations with customers concerning these costs; competitive challenges from existing and new competitors, including original equipment manufacturer (“OEM”) customers; the challenges associated with rapidly changing technologies, and our ability to innovate in response; the difficulty in forecasting demand for electric vehicles and our electric vehicles revenue growth; future changes in laws and regulations, including, by way of example, taxes and tariffs, in the countries in which we operate; potential disruptions in the global economy caused by wars or other geopolitical conflicts; the ability to identify targets and consummate acquisitions on acceptable terms; failure to realize the expected benefits of acquisitions on a timely basis; the possibility that our 2023 tax-free spin-off of our former Fuel Systems and Aftermarket segments into a separate publicly traded company will not achieve its intended benefits; the failure to promptly and effectively integrate acquired businesses; the potential for unknown or inestimable liabilities relating to the acquired businesses; impacts of our exit of the charging business; our dependence on automotive and truck production, which is highly cyclical and subject to disruptions; our reliance on major OEM customers; impacts of any future strikes involving any of our OEM customers and any actions such OEM customers take in response; fluctuations in interest rates and foreign currency exchange rates; our dependence on information systems; the uncertainty of the global economic environment; ; the uncertainty surrounding global trade policies, including tariffs and export restrictions, and their impacts on the Company, its customers and suppliers and the economies in which the Company operates; the outcome of existing or any future legal proceedings, including litigation with respect to various claims, or governmental investigations, including related litigation; impacts from any potential future acquisition or disposition transactions; and the other risks, noted in reports that we file with the Securities and Exchange Commission, including Item 1A, “Risk Factors” in our most recently-filed Form 10-K and/or Quarterly Report on Form 10-Q. We do not undertake any obligation to update or announce publicly any updates to or revisions to any of the forward-looking statements in this release to reflect any change in our expectations or any change in events, conditions, circumstances, or assumptions underlying the statements.

### **Contact presse :**

Morvyn Lipinski

Phone +49 6151 800 500 440

[mediacontact.eu@borgwarner.com](mailto:mediacontact.eu@borgwarner.com)