

### **BorgWarner liefert integriertes 7-in-1 Antriebsmodul an führenden chinesischen OEM**

- *Das 7-in-1 iDM unterstützt die fortschrittliche Hybridtechnologie des Kunden*
- *Innovative Technologie für bessere Fahrzeugperformance und höhere Effizienz*
- *Integration mehrerer Funktionen in einer Einheit ermöglicht Kostenvorteile*

Auburn Hills, Michigan, 12. November 2025 – BorgWarner hat einen Auftrag zur Lieferung des integrierten 7-in-1 Antriebsmoduls (iDM) an einen führenden chinesischen Automobilhersteller erhalten. Das speziell für ein Hybrid-SUV entwickelte iDM kombiniert mehrere Funktionen in einem kompakten Modul und verbessert so Leistung und Effizienz. Der Produktionsstart ist 2026 geplant.

„Dank unserer Expertise in der Entwicklung von Komponenten und Systemen sind wir optimal aufgestellt, eine leistungsstarke und individuell abgestimmte iDM-Architektur für die Hybridanwendung unseres Kunden zu entwickeln“, erklärte Dr. Stefan Demmerle, President und General Manager, BorgWarner PowerDrive Systems. „Wir freuen uns, unsere Technologie einem wichtigen Hersteller in dieser Region zur Verfügung zu stellen.“

Das 7-in-1 iDM von BorgWarner vereint zwei Elektromotoren mit High-Voltage-Hairpin-Technologie, Doppel-Inverter samt integriertem Onboard-Charger, DC/DC-Wandler, Spannungsverstärkung der Batterie, Funktionen für VCU und PDU sowie ein eGear-Getriebe in einer kompakten Einheit. Jedes Modul ist skalierbar und bietet hohe Integrations- und Effizienzgrade. Das System kann bis zu 160 kW Leistung bei einer maximalen Betriebsspannung von 450 V bereitstellen, erzeugt ein Spitzendrehmoment von über 3.400 Nm und erreicht eine Höchstdrehzahl von 1.350 U/min.

BorgWarner verfügt über umfassende Kompetenz im Bereich elektrifizierter Antriebssysteme sowie vollständige Inhouse-Expertise für Elektromotoren, Leistungselektronik und Getriebe. Das Unternehmen bietet flexible, hochintegrierte Lösungen, die individuell auf die Anforderungen der Kunden abgestimmt sind. Das Unternehmen setzt auf Qualität, technisches Know-how und Kooperation mit OEM-Partnern, um Innovationen voranzubringen und das Wachstum des chinesischen Markts für New Energy Vehicles zu fördern.

## Über BorgWarner

BorgWarner bringt als globaler Produktführer seit mehr als 130 Jahren erfolgreich Mobilitätsinnovationen auf den Markt. Mit unserem Fokus auf Nachhaltigkeit tragen wir dazu bei, eine saubere, gesunde und sichere Zukunft zu schaffen.

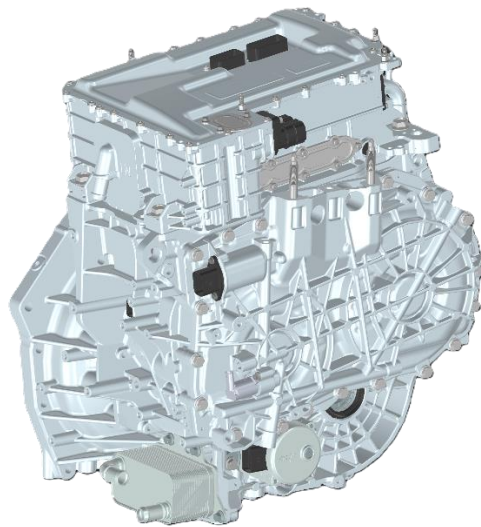

BorgWarner liefert integriertes 7-in-1 Antriebsmodul an führenden chinesischen OEM

**Forward Looking Statements:** This release may contain forward-looking statements as contemplated by the 1995 Private Securities Litigation Reform Act that are based on management’s current outlook, expectations, estimates and projections. Words such as “anticipates,” “believes,” “continues,” “could,” “designed,” “effect,” “estimates,” “evaluates,” “expects,” “forecasts,” “goal,” “guidance,” “initiative,” “intends,” “may,” “outlook,” “plans,” “potential,” “predicts,” “project,” “pursue,” “seek,” “should,” “target,” “when,” “will,” “would,” and variations of such words and similar expressions are intended to identify such forward-looking statements. Further, all statements, other than statements of historical fact, contained or incorporated by reference in this release that we expect or anticipate will or may occur in the future regarding our business strategy, goals, plans, references to future success and other such matters, are forward-looking statements. All forward-looking statements are based on assumptions and analyses made by us in light of our experience and our perception of historical trends, current conditions and expected future developments, as well as other factors we believe are appropriate under the circumstances. Forward-looking statements are not guarantees of performance, and the Company’s actual results may differ materially from those expressed, projected or implied in or by the forward-looking statements.

You should not place undue reliance on these forward-looking statements, which speak only as of the date of this release. Forward-looking statements are subject to risks and uncertainties, many of which are difficult to predict and generally beyond our control, that could cause actual results to differ materially from those expressed, projected or implied in or by the forward-looking statements. These risks and uncertainties, among others, include: evolving legal, regulatory, and tax regimes; the supply disruptions impacting us or our customers, commodity availability and pricing, and an inability to achieve expected levels of recoverability in commercial negotiations with customers concerning these costs; competitive challenges from existing and new competitors, including original equipment manufacturer (“OEM”) customers; the challenges associated with rapidly changing technologies, and our ability to innovate in

## BorgWarner Inc. (BorgWarner to Supply Leading Chinese OEM with 7-in-1 Integrated Drive Module) – 3

response; the difficulty in forecasting demand for electric vehicles and our electric vehicles revenue growth; future changes in laws and regulations, including, by way of example, taxes and tariffs, in the countries in which we operate; potential disruptions in the global economy caused by wars or other geopolitical conflicts; the ability to identify targets and consummate acquisitions on acceptable terms; failure to realize the expected benefits of acquisitions on a timely basis; the possibility that our 2023 tax-free spin-off of our former Fuel Systems and Aftermarket segments into a separate publicly traded company will not achieve its intended benefits; the failure to promptly and effectively integrate acquired businesses; the potential for unknown or inestimable liabilities relating to the acquired businesses; impacts of our exit of the charging business; our dependence on automotive and truck production, which is highly cyclical and subject to disruptions; our reliance on major OEM customers; impacts of any future strikes involving any of our OEM customers and any actions such OEM customers take in response; fluctuations in interest rates and foreign currency exchange rates; our dependence on information systems; the uncertainty of the global economic environment; ; the uncertainty surrounding global trade policies, including tariffs and export restrictions, and their impacts on the Company, its customers and suppliers and the economies in which the Company operates; the outcome of existing or any future legal proceedings, including litigation with respect to various claims, or governmental investigations, including related litigation; impacts from any potential future acquisition or disposition transactions; and the other risks, noted in reports that we file with the Securities and Exchange Commission, including Item 1A, "Risk Factors" in our most recently-filed Form 10-K and/or Quarterly Report on Form 10-Q. We do not undertake any obligation to update or announce publicly any updates to or revisions to any of the forward-looking statements in this release to reflect any change in our expectations or any change in events, conditions, circumstances, or assumptions underlying the statements.

### **PR-Kontakt:**

Morvyn Lipinski

Phone: +49 6151-800-500-440

E-Mail: [mediacontact.eu@borgwarner.com](mailto:mediacontact.eu@borgwarner.com)