

## **BorgWarner to Supply Leading Chinese OEM with 7-in-1 Integrated Drive Module**

- *Customized 7-in-1 iDM supports the customer's advanced next generation hybrid technology*
- *Innovative technology for better vehicle performance and driving efficiency*
- *Integration of technologies offers cost savings*

Auburn Hills, Michigan, October 30, 2025 – BorgWarner has secured a contract to supply its 7-in-1 Integrated Drive Module (iDM) to a leading Chinese original equipment manufacturer (OEM). Exclusively designed for the customer's hybrid SUV, BorgWarner's iDM integrates multiple functions within a single compact unit to boost overall system performance and efficiency, with mass production scheduled to begin in 2026.

"Our component and system expertise puts us in an ideal position for developing a highly efficient and customized iDM architecture for our customer's hybrid application," said Dr. Stefan Demmerle, Vice President of BorgWarner Inc. and President and General Manager, PowerDrive Systems. "We're proud to be supplying our technology to such a prominent manufacturer in this region."

BorgWarner's 7-in-1 iDM combines two electric motors featuring the company's patented high voltage hairpin winding technology, a dual inverter integrated with on-board charger (OBC), DCDC converter, battery voltage boost, vehicle control unit (VCU) and power distribution unit (PDU) functions, as well as an eGear transmission - all within a single compact unit. Each component of the module is scalable for design flexibility, offering high levels of integration and efficiency. The system supports power requirements up to 160 kW with a peak operating voltage of 450V, delivers peak drive torque exceeding 3,400 Nm, and achieves a maximum speed of 1,350 r/min.

With deep expertise in electrified propulsion and full-stack in-house capabilities covering e-motors, power electronics, and gearboxes, BorgWarner provides flexible and highly integrated solutions tailored to customer needs. Supported by proven product quality, strong technical capabilities, and close collaboration with OEM partners, the company remains committed to

## BorgWarner Inc. (BorgWarner to Supply Leading Chinese OEM with 7-in-1 Integrated Drive Module) – 2

driving technology upgrades and supporting the rapid development of China's new energy vehicle market.

### About BorgWarner

For more than 130 years, BorgWarner has been a transformative global product leader bringing successful mobility innovation to market. With a focus on sustainability, we're helping to build a cleaner, healthier, safer future for all.

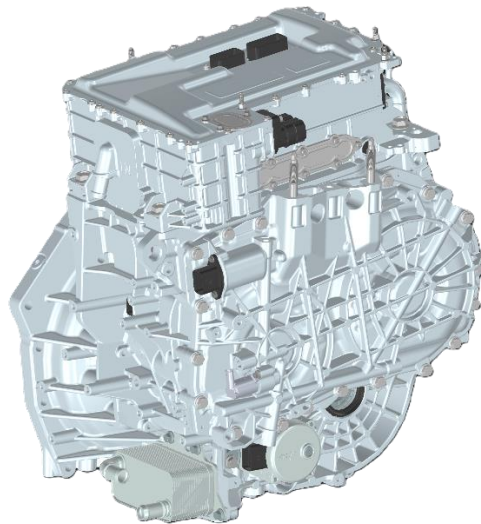

### BorgWarner to Supply Leading Chinese OEM with 7-in-1 Integrated Drive Module

**Forward Looking Statements:** This release may contain forward-looking statements as contemplated by the 1995 Private Securities Litigation Reform Act that are based on management's current outlook, expectations, estimates and projections. Words such as "anticipates," "believes," "continues," "could," "designed," "effect," "estimates," "evaluates," "expects," "forecasts," "goal," "guidance," "initiative," "intends," "may," "outlook," "plans," "potential," "predicts," "project," "pursue," "seek," "should," "target," "when," "will," "would," and variations of such words and similar expressions are intended to identify such forward-looking statements. Further, all statements, other than statements of historical fact, contained or incorporated by reference in this release that we expect or anticipate will or may occur in the future regarding our business strategy, goals, plans, references to future success and other such matters, are forward-looking statements. All forward-looking statements are based on assumptions and analyses made by us in light of our experience and our perception of historical trends, current conditions and expected future developments, as well as other factors we believe are appropriate under the circumstances. Forward-looking statements are not guarantees of performance, and the Company's actual results may differ materially from those expressed, projected or implied in or by the forward-looking statements.

You should not place undue reliance on these forward-looking statements, which speak only as of the date of this release. Forward-looking statements are subject to risks and uncertainties, many of which are difficult to predict and generally beyond our control, that could cause actual results to differ materially from those expressed, projected or implied in or by the forward-looking statements. These risks and uncertainties, among others, include: evolving legal, regulatory, and tax regimes; the supply disruptions impacting us or our customers, commodity availability and pricing, and an inability to achieve expected levels of recoverability in commercial negotiations with customers concerning these costs; competitive challenges from existing and new competitors, including original equipment manufacturer

## BorgWarner Inc. (BorgWarner to Supply Leading Chinese OEM with 7-in-1 Integrated Drive Module) – 3

(“OEM”) customers; the challenges associated with rapidly changing technologies, and our ability to innovate in response; the difficulty in forecasting demand for electric vehicles and our electric vehicles revenue growth; future changes in laws and regulations, including, by way of example, taxes and tariffs, in the countries in which we operate; potential disruptions in the global economy caused by wars or other geopolitical conflicts; the ability to identify targets and consummate acquisitions on acceptable terms; failure to realize the expected benefits of acquisitions on a timely basis; the possibility that our 2023 tax-free spin-off of our former Fuel Systems and Aftermarket segments into a separate publicly traded company will not achieve its intended benefits; the failure to promptly and effectively integrate acquired businesses; the potential for unknown or inestimable liabilities relating to the acquired businesses; impacts of our exit of the charging business; our dependence on automotive and truck production, which is highly cyclical and subject to disruptions; our reliance on major OEM customers; impacts of any future strikes involving any of our OEM customers and any actions such OEM customers take in response; fluctuations in interest rates and foreign currency exchange rates; our dependence on information systems; the uncertainty of the global economic environment; ; the uncertainty surrounding global trade policies, including tariffs and export restrictions, and their impacts on the Company, its customers and suppliers and the economies in which the Company operates; the outcome of existing or any future legal proceedings, including litigation with respect to various claims, or governmental investigations, including related litigation; impacts from any potential future acquisition or disposition transactions; and the other risks, noted in reports that we file with the Securities and Exchange Commission, including Item 1A, “Risk Factors” in our most recently-filed Form 10-K and/or Quarterly Report on Form 10-Q. We do not undertake any obligation to update or announce publicly any updates to or revisions to any of the forward-looking statements in this release to reflect any change in our expectations or any change in events, conditions, circumstances, or assumptions underlying the statements.

**PR contact:**

Michelle Collins

Phone: +1 248-754-0449

Email: [mediacontact@borgwarner.com](mailto:mediacontact@borgwarner.com)